

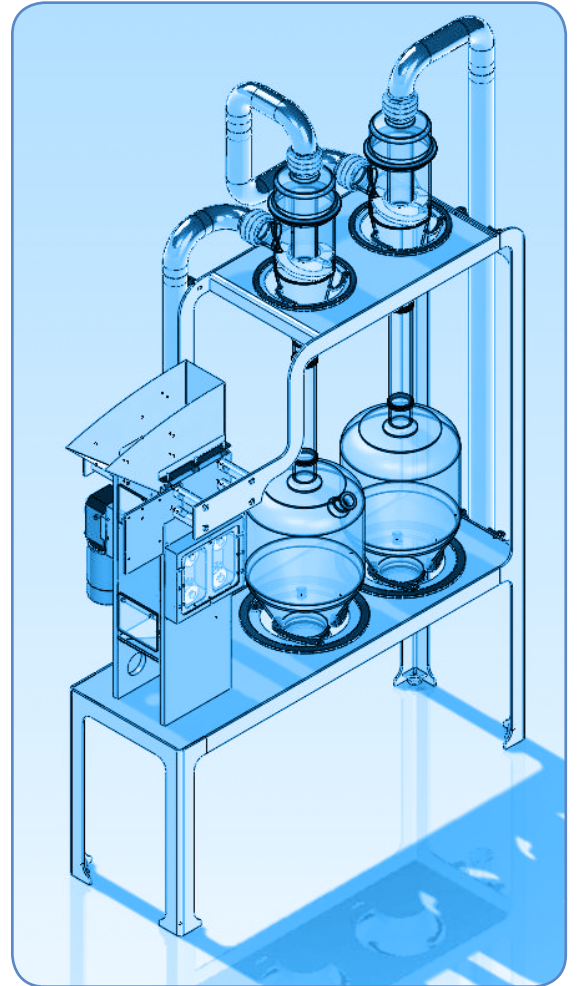

VORTEX WINNOWER - SINGLE

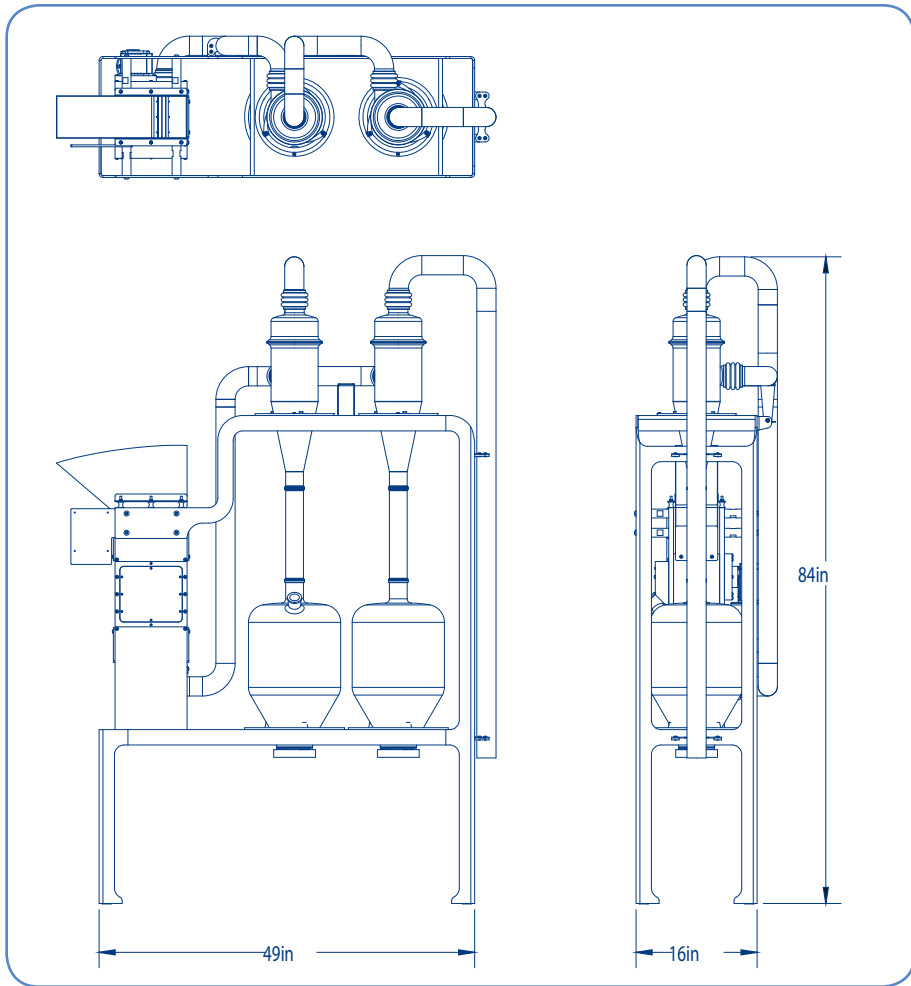

Specifications:

Footprint: 49" x 16"

Winnowing Speed: 20kg / hour nominal (adjustable)

Electrical:

Cracker/Feeder : 110 V 4 amps

Vacuum: 110 V 9 amps

Efficiency:

Nib loss: 0.25 % depending on bean quality

Shell content in nibs: 0.20% depending on bean quality and machine running speed

All aluminum components are anodized and the frame is powder coated FDA white.

Description:

This revolutionary design is based on a new and inventive technology of separating nibs from husks using Vortex tubes.

The machine was specifically designed to be a showpiece for Artisanal manufacturers, enhancing the experience of visiting customers.

For more details and explanation of operation, please visit www.brooklyncacao.com

*PATENT PENDING

BROOKLYN CACAO | 218 Conover Street | Brooklyn, NY | 11231 | 347-225-0130 | www.brooklyncacao.com

BROOKLYN CACAO designs and custom builds medium scale production machinery for artisanal beans-to-bar chocolate manufacture.

PROPRIETARY AND CONFIDENTIAL: THE INFORMATION CONTAINED IN THIS DRAWING IS THE SOLE PROPERTY OF CACAO HOLDINGS. ANY REPRODUCTION IN PART OR AS A WHOLE WITHOUT THE WRITTEN PERMISSION OF CACAO HOLDINGS IS PROHIBITED.